



7 SERIES DUAL FUEL RANGES

Viking 7 Series – VDR

COMMERCIAL-TYPE COOKING POWER

- **EXCLUSIVE** Viking Elevation™ Burners with brass flame ports boast 23,000 BTUs across the front of all width configurations, with multiple 15,000 BTUs and one 8,000 BTU burner across the rear
- Three burner sizes efficiently deliver heat to any size cookware
- **EXCLUSIVE** VariSimmer™ Setting on ALL burners provides gentle, even simmering at precisely low cooking temperatures
- **EXCLUSIVE** SureSpark™ Ignition System, ensures automatic ignition/re-ignition, should the burners extinguish at any time while cooking

REVERSIBLE GRIDDLE/GRILL

- Thermostatically controlled non-stick griddle heats evenly to provide consistent cooking across the entire surface and can be easily removed for cleaning
- Reversible Griddle/Grill features the PATENT PENDING StayCool™ Trough Handle and grease containment system that strategically directs excess grease into a removable capture trough for quick and easy cleanup
- Optional ViChrome™ Griddle accessory interchanges with the non-stick griddle providing versatility for griddling and easy cleanup

INNOVATIVE FEATURES

- **EXCLUSIVE** GentleClose™ Door allows the door to slowly close, ensuring delicate baked goods are not disturbed
- **EXCLUSIVE** TruGlide™ Full Extension Racks for safe and easy removal of heavy bakeware
- **EXCLUSIVE** BlackChrome™ Knobs with CoolLit™ LED Backlighting

EASY OPERATION AND CLEANUP

- **EXCLUSIVE** seamless, heavy gauge porcelain burner pan with elevated flame ports prevent spillovers from baking on, making cleanup easy
- Continuous grate design allows easy movement of pots and pans from burner to burner
- Preheat Optional - No need to preheat oven when baking certain foods in Convection Bake mode (right oven of 48"W. model)
- Self-clean oven
- Grates, burner caps, knobs, griddle and accessories can be easily removed and taken to the sink for cleaning



DUAL FUEL OVEN FUNCTIONS

- Largest self-clean oven in the industry has enough space to accommodate various size bakeware for multi-rack cooking
- PATENTED Vari-Speed Dual Flow™ Convection System has the largest fan in the industry; the 8 1/2" two-speed fan works bi-directionally for maximum airflow and excellent cooking results
- 12 high-performance cooking modes: bake, convection bake, TruConvec™ Convection Cooking, convection roast, hi, med and low broil, convection broil, convection dehydrate, convection defrost, proof (left oven on 48"W. range), and self-clean
- **EXCLUSIVE** GourmetGlo™ Infrared Broiler provides intense heat to lock in savory juices (right oven on 48"W. range)
- Concealed 10 pass dual bake element provides precise temperature control (right oven on 48"W. range)
- Concealed four pass bake element (left oven on 48"W. range)
- **EXCLUSIVE** Rapid Ready™ Preheat provides one of the fastest preheat times - so your oven is ready to begin cooking when you are (right oven on 48"W. range)

MODEL NUMBERS

- VDR73626B – 36."W. Dual Fuel Range; 6 burners
- VDR73624G – 36."W. Dual Fuel Range; 4 burners with griddle
- VDR74828B – 48."W. Dual Fuel Range; 8 burners
- VDR74826G – 48."W Dual Fuel Range; 6 burners with griddle

ACCESSORIES

- BG107362SS – 10"H. backguard for 36" range
- BG107482SS – 10"H. backguard for 48" range
- HS24736SS – 24"H. high shelf for 36" range
- HS24748SS – 24"H. high shelf for 48" range
- P36CRTSS – countertop rear trim for 36" range
- P48CRTSS – countertop rear trim for 48" range
- CRG7VGR – ViChrome Griddle (for use with griddle model)
- LPKVGR – LP/Propane conversion kit for 7 Series
- GCKVGR – gas connector kit
- CBGVGR – bamboo cover for griddle
- WOKVGR7 – wok ring accessory

COLOR FINISHES

- Stainless Steel (SS)
- Available in 18 Exclusive Color Finishes: Antique Bronze (AN), Blush (BH), Cast Black (CS), Daffodil (DA), Damascus Gray (DG), Eucalyptus (EU), Golden Hour (GH), Ivy (IV), Martini (MA), Nantucket (NA), November Sky (NS), Onyx (ON), Pure White (PW), Slate Blue (SB), Spiced Cider (SC), Squall (SQ), Splash (SP), and Valentine (VA)



WARRANTY

- 2-year full – complete product
- 90-day full – cosmetic parts such as glass, painted items and decorative items
- 5-year limited – gas burners



7 SERIES DUAL FUEL RANGES

Viking 7 Series – VDR

DUAL FUEL 36" AND 48" W. RANGES		
DESCRIPTION	VDR73626B/VDR73624G	VDR74828B/VDR74826G
Overall Width	35-7/8" (91.1 cm)	47-7/8" (121.6 cm)
Overall Height	To top of side trim – 35-15/16" (91.3 cm) min. 37-9/16" (95.4 cm) max. Legs adjust – 1-5/8" (4.1 cm)	
Overall Depth from Rear*	To end of side panel – 25-1/4" (64.1 cm) To front of door – 26-15/16" (68.4 cm) To end of door handle – 30" (76.2 cm) *Add 3/4" (1.9 cm) to overall depth for models installed against a combustible wall.	
Additions to Base Height	To top of island trim – add 1" (5 cm) To top of backguard – add 10" (25.4 cm) To top of high shelf – add 24-1/8" (61.3 cm)	
Gas Manifold Pressure	Natural 5.0" W.C.P./ Liquid Propane LP 10.0" W.C.P.	
Surface Burner Rating Natural Gas/LP	Front: (3) 23,000 BTU (6.7 kW) / 20,000 BTU (5.9 kW) Rear: (2) 15,000 BTU (4.4 kW) / 13,500 BTU (4.0 kW) (1) 8,000 BTU (2.3 kW) / 8,000 BTU (2.3 kW)	Front: (4) 23,000 BTU (6.7 kW) / 20,000 BTU (5.9 kW) Rear: (3) 15,000 BTU (4.4 kW) / 13,500 BTU (4.0 kW) (1) 8,000 BTU (2.3 kW) / 8,000 BTU (2.3 kW)
Griddle Burner Rating	15,000 BTU Nat./13,500 BTU LP (4.4 kW Nat./4.0 kW LP)	
Gas Requirements	Shipped Natural or LP/Propane, accepts standard residential 1/2" (1.3 cm) ID gas service line. Unit is field convertible with proper conversion kit	
Electrical Requirements	See Electrical Requirements information in installation guide	
Maximum Amp Usage	240V - 28.5 amps / 208V - 24.7 amps	240V - 43.0 amps / 208V - 37.3 amps
Oven Interior Width	30-5/16" (77.0 cm)	Right oven - 25-5/16" (64.3 cm) / Left oven - 13-3/4" (34.9 cm)
Oven Interior Height	16-1/2" (41.9 cm)	
Oven Interior Depth Overall Measured To Aham Standard**	19-1/2" (41.9 cm) 16-13/16" (42.7 cm)	
Oven Volume Overall Measured to Aham Standard**	5.6 cu. ft. 4.9 cu. ft.	Right - 4.7 cu. ft. / Left - 2.6 cu. ft. Right - 4.1 cu. ft. / Left - 2.2 cu. ft.
Approximate Shipping Weight	505 lbs. (229.1 kg)	684 lbs. (310.3 kg)

Please do not prepare installation from brochure data only. See installation instructions for important clearance/installation information.
**The AHAM Standard for measuring oven capacity subtracts the door plug and convection baffle dimension from the total oven volume.

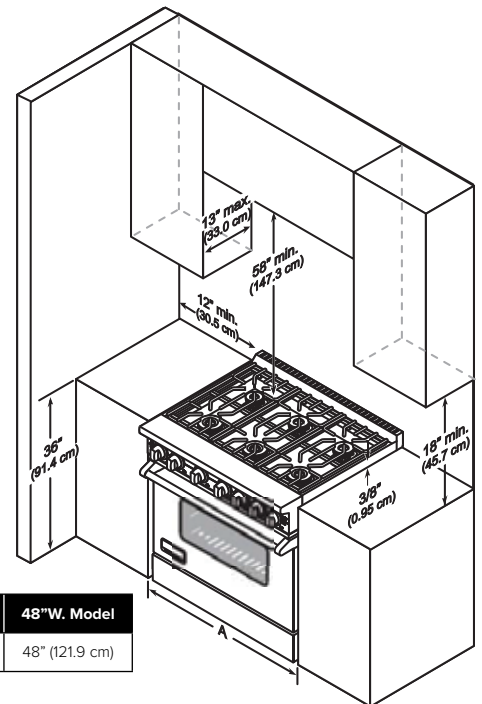
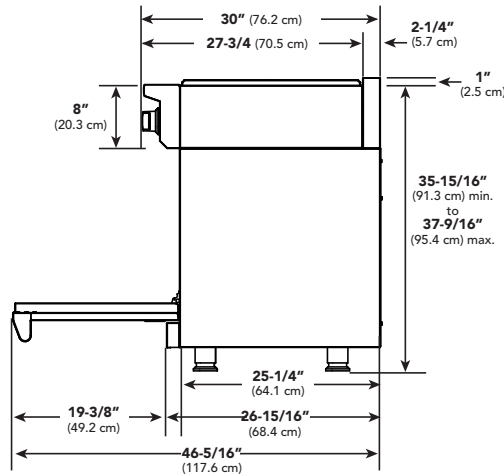
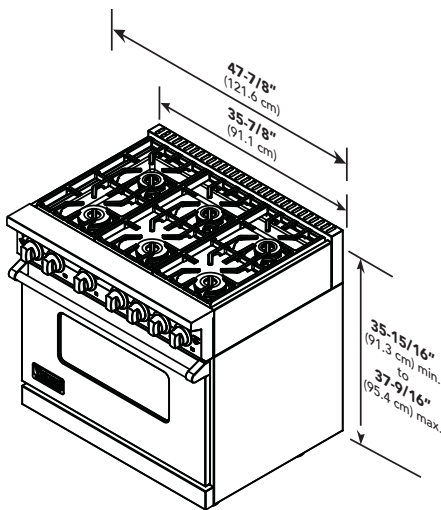

	36"W. Model	48"W. Model
A	36" (91.4 cm)	48" (121.9 cm)



VIKING RANGE, LLC 111 FRONT STREET GREENWOOD, MISSISSIPPI 38930 USA

For detailed product information, model numbers, or to request a quote call 1-888-845-4641 or visit vikingrange.com
© 2024 Viking Range, LLC All rights reserved. Specifications subject to change without notice.

